

BF pallet track pump

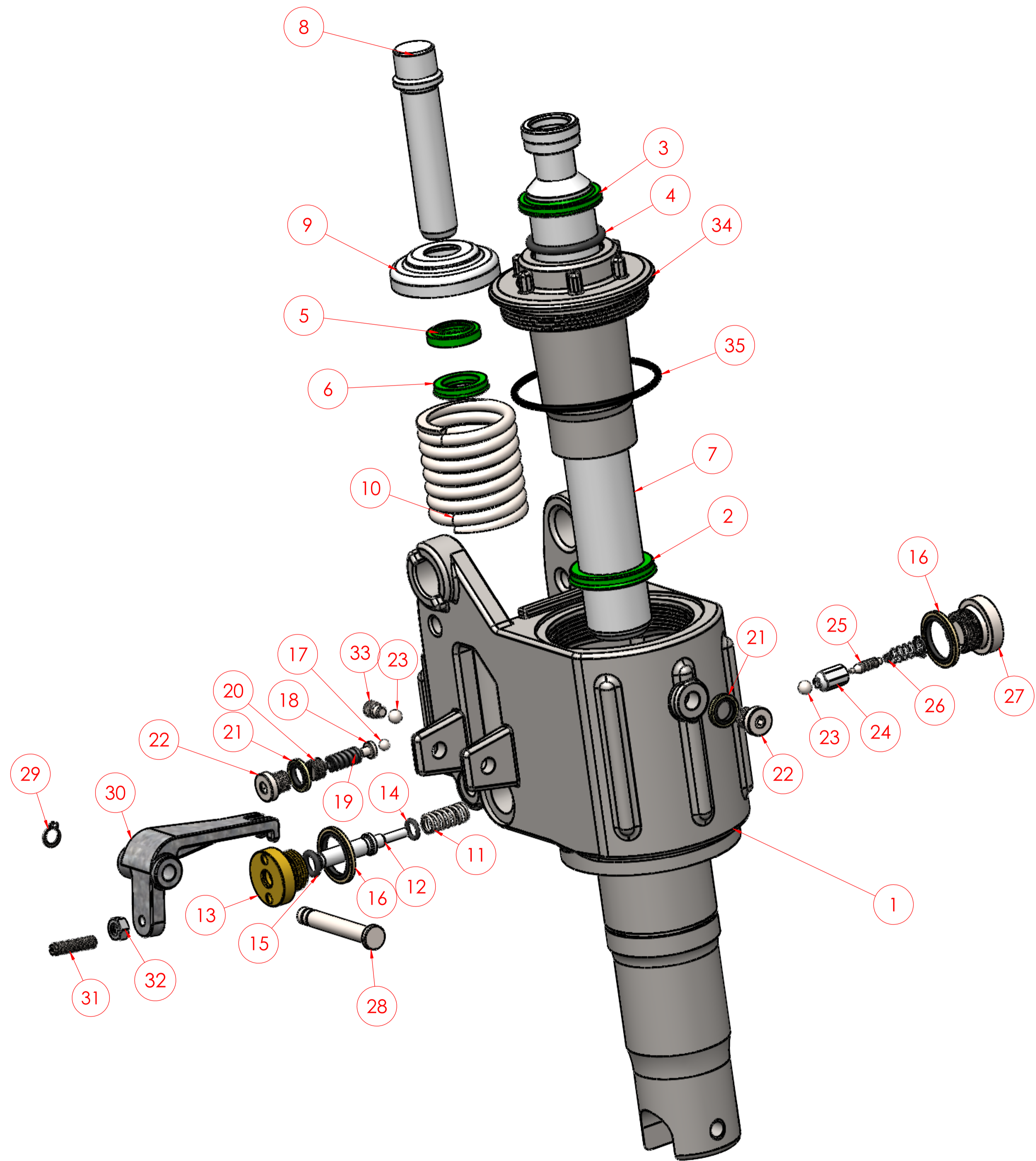

ITEM NO.	PART NUMBER	DESCRIPTION	QTY.
1	1-15-03010051	Pump body	1
2	1-14-080002	UHS 31.5	1
3	1-14-080001	Dust ring 31.5	1
4	1-14-070003	O-ring 31.5x3.55	1
5	1-140-80003	Dust ring 18	1
6	1-14-080004	UHS 18	1
7	1-15-03010019	Piston rod 31.5 x 263	1
8	1-15-03010026	Pump plunger 18	1
9	1-15-03010038	Plunger washer	1
10	1-16-040007	Plunger spring	1
11	1-16-040003	Spring 1.2x9.8x22	1
12	1-15-03010031	Strike pin	1
13	1-16-030007	Seat of strike pin(brass plug)	1
14	1-14-070001	O-ring 6.9x1.8	1
15	1-14-070002	Oring 8x2.65	1
16	1-14-050002	Copper washer 20	2
17	1-14-120002	Steel ball 5	1
18	1-15-03010041	Ball base	1
19	1-16-040002	Spring 2 x 8 x 16	1
20	1-16-030011	Bolt M10x1	1
21	1-14-050001	Copper washer 10	2
22	1-16-030002	Plug M10x1	2
23	1-14-120001	Steel ball 6.35	2
24	1-16-050001	Seat of valve	1
25	1-16-050002	Spindle of valve	1
26	1-16-040001	conical spring	1
27	1-16-030004	Plug M20 x1.5	1
28	1-14-030008	pin 8 x 58	1
29	1-14-160004	Ring for axle 8	1
30	1-15-03010035	Lever plate	1
31	1-16-030006	Bolt M6 x 25	1
32	1-14-020001	HexNut M6 x1	1
33	1-16-030014	Bolt M8 x 10.25	1
34	1-15-03010014	Cylinder cap 31.5	1
35	1-14-070004	O-ring 65 x 2.65	1